

# Valve Positioners series 700FC

► Electro-Pneumatic / Pneumatic to Pneumatic. (Rotary / Linear)



## Description

The FLUCON 700 FC series positioners converts a controller output (usually 3 to 15 psig or 4 to 20m ADC) to Linearly/Rotary proportional Travel/Rotation & Pneumatic outputs. The Positioners are based on a force balance design for control applications that requires a high degree of reliability & repeatability at an economical cost. Optional NEMA 4X (IP65/IP66)-explosion proof versions allows for splashdown/explosive atmosphere and outdoor installation.

The FLUCON 700 FC series positioners are available in two different versions namely Pneumatic to Pneumatic & Electro-Pneumatic, both can be used for Linear/Rotary movement with ranges 3-9 and 9-15 psig control signal, when you select split range. Standard range is 3-15 psig. The positioners can handle the supply pressure upto 100 psig for higher pressure Industrial pneumatic and process control system requirements.

## Principle of Operation

The operation of FLUCON 700 FC series positioners is based on a force balanced system. Tension on the feedback spring provides feedback to the positioner which will vary as the actuator shaft rotates with cam. The spring loading force is applied through the cam shaft & cam to the positioner's instrument signal capsule through the balance beam.

Output from the controller (usually 3-15 Psig) is applied to the diaphragm in the instrument signal capsule serving as a force balance membrane, matching the actuator shaft position to the instrument signal.

## Split Ranging

If split ranging is required the cam should be readjusted for 3-9 psig or 9-15 psig input signal and should be recalibrated. The standard is 3-15 psig input signal.

## Mounting

The FLUCON 700 FC series positioners may be mounted on Linear Actuator/Rotary Actuator as per installation and operational manual.

## Field Reversible

To change from direct acting to reverse acting simply reverse the cam and fix it on cam shaft and make sure of the signal SPAN which is printed on the cam and recalibrate for Actuator fully open or close position incase of Pneumatic to Pneumatic. For Electro-Pneumatic change current signal input leads from positive to negative and change current signal from 4-20 to 20-4 over and above cam reverse and recalibrate the Positioner.

## ► Integrated Characteristics

- Suitable for Rotary / Linear Actuators.
- Low Air Consumption.
- Corrosion-Resistance Aluminium Diecast Body.
- Simple Conversion to Direct Acting or Reverse Acting.
- Precise Calibration with simple SPAN and Zero Adjustments.
- Suitable for Single/Double acting Actuators.
- Split Ranging.
- Optional Built-in Limit Switches or 4-20mA Position Transmitter for feedback.
- Extremely Vibration Resistance Design.
- Easy Maintenance.

## ► Application

The Flucon 700FC Positioners converts pneumatic/electrical signal to a pneumatic output which can be used to operate the following:

- Valve, Valve-Actuators
- Damper and Louver Actuators
- Air-Cylinders
- Relays
- Clutches
- Web Tensioners and Brakes

## Used in :

- Petrochemical Processing Systems
- Energy Management
- Hvac Systems
- Textile Processing Systems
- Phamraceutical Processing System
- Paper & Pulp Handling Controls

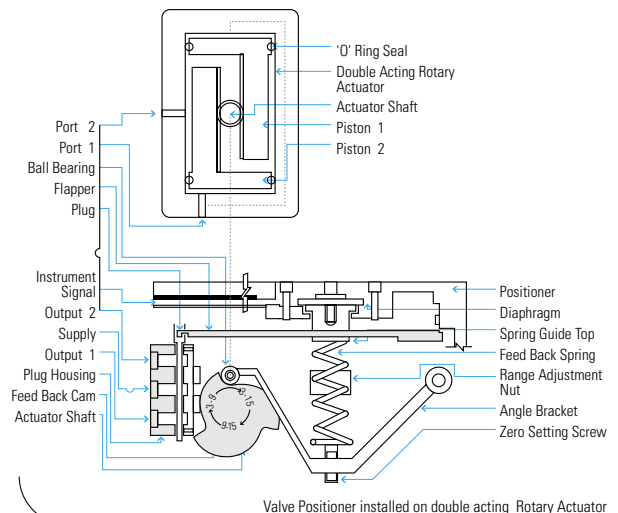

Valve Positioner installed on double acting Rotary Actuator

► **Specifications**

**Pneumatic to Pneumatic series 700FC**

Range	3 to 15 psig
Split Range	3 to 9 or 9 to 15 psig
Travel	Linear / Rotary
Min./Max. Supply Pressure	Minimum - 30 psig (210 kPa), Maximum -150 psig (1050 kPa)
Supply Pressure Sensitivity	0.5% of span per psig 0.2% of span per 10 kPa)
Linearity	1.0% of span
Repeatability	0.5% of span
Media	Oil free, clean dry air filtered to 40 micron
Temp. Range (Operating)	-30C to 60C (-20F to 140F)
Port Sizes	1/4" BSP (Pneumatic)
Weight	3.5 lbs. (1.5 kgs.)

**FC703 E/P Rotary Positioner**

Rotary type cam feedback  
Single / Double action

**FC704 E/P Linear Positioner**

Lever type lever feedback  
Single / Double action

Input Signal	4-20 mADC	
Input Resistance	25015 (4-20 mADC)	
Supply Air Pressure	1.4 -7 kgf/cm <sup>2</sup> (20-100 psig)	
Standard Stroke	0-90	10-150mm
Linearity	2.0% F.S.	1.0% F.S.
Hysteresis		1% F.S.
Sensitivity	0.5 F.S.	0.2% F.S.
Repeatability		0.5%
Air Consumption	3LPM (Supply 1.4kgf/cm <sup>2</sup> , 20psig)	
Flow Capacity	80LPM (Supply 1.4kgf/cm <sup>2</sup> , 20psig)	
Air Connection	1/4" NPT	
Gauge Connection	1/8" NPT	
Electrical Connection	G 1/2" Female	
Explosion Proof*	Exdm IIB (C) T6, Exia IIB T6 (IIa, IIb and IIc)	
Protection	IP 66	
Ambient Temperature	-20C to 70C	
Material	Aluminium Alloy	
Weight	2.8 kg. (6.2lbs) approx.	

► **Ordering Information Valve Positioners series 700 FC**

Part No.	Description
FC 701	Rotary Valve Positioner
Options	01 Rotary Valve Positioner with Feedback O/P
	02 Rotary Valve Positioner with Dom Type Position Indicator
	03 Rotary Valve Positioner with On-Off Limit Switch.
FC 702	Linear Valve Positioner
Options	01 Linear Valve Positioner with Feedback O/P
	02 Linear Valve Positioner with On-Off Limit Switch.
FC 703	Electro - Pneumatic Rotary Valve Positioner
FC 704	Electro - Pneumatic Linear Valve Positioner
Options	01 Position Transmitter (4-20mADC)

► **Options**

Add proper letter onto end of part no.

G- Pressure Gauge : 2" face, back mounted Dual scale.

W-NEMA 4X : Enclosure for splashdown/outdoor use.

Ex- : Explosion-proof

► **Note :**

Consult factory for Electro-pneumatic Transducers (current/voltage input), Position Transmitters and Limit Switches.

► The above represents the performance of the positioner on an Actuator without a valve.  
\*Approval Pending

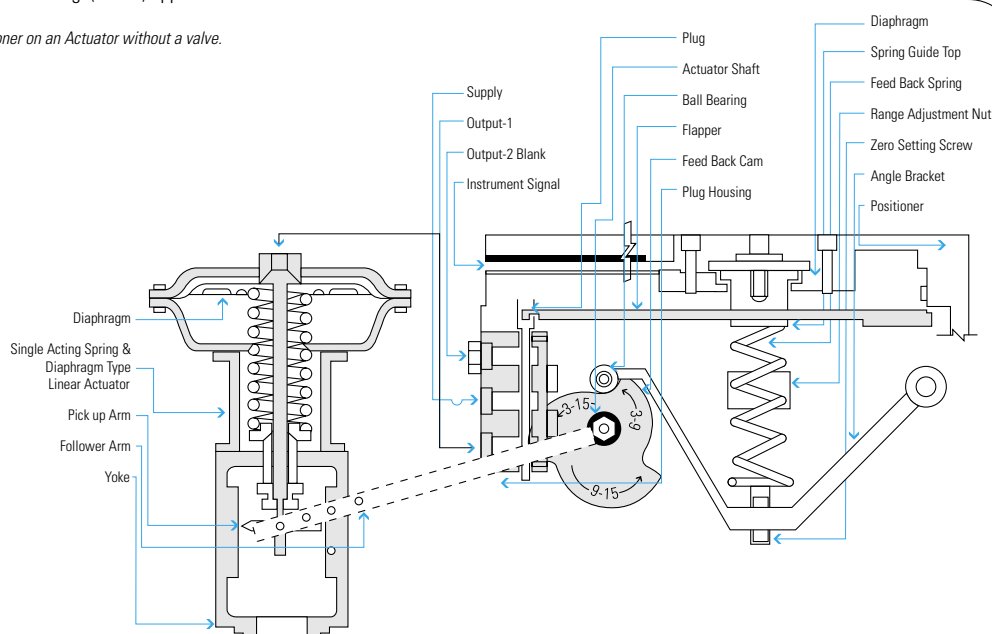

Valve Positioner installed on Linear single acting Diaphragm Actuator

**Prisma Automation**

**ZI Les Paluds – Rue de Lenche, Lot n° 4  
13400 Aubagne - FRANCE**

**Tél. : +33 (0) 4 42 72 17 40**

**Fax : +33 (0) 4 42 72 17 41**

**<http://www.prismaautomation.com>**